

MINOLTA

DiALTA Color™

CF3102

The essentials of imaging



31 COLOR
pages/min
A4 crosswise



THE COLOR OF SUCCESS.

Create Business Success With The Powerful Performance Of The Minolta DiALTA Color CF3102



Now more than ever to achieve success, today's offices need superior creative solutions, brilliant and reliable performance, plus impressive results that are delivered quickly and effectively. Introducing the multifunctional Minolta DiALTA Color CF3102 - the new standard in next-generation colour image information products. You demand crisp, clear colour reproductions as dynamic and delicate as the original for outstanding business materials. You require convincing documents rapidly in both colour and black & white. You need the advantages of intelligent and versatile networking capabilities that allow workgroups to share valuable information assets for seamless communication and smooth workflow. Boost the overall productivity of your office with the fast, dynamic and efficient DiALTA Color CF3102. The all-in-one colour solution for your business success.

Get Powerful Business Support from the Minolta DiALTA Color CF3102

Minolta offers a wide variety of solutions to meet your office's colour needs.



MFP (Multi-Functional Peripherals) Version

For offices in need of document sharing among workgroups, integrating the management of paper documents and document files, as well as copying and printing both colour and black & white documents.

CN3102e*1 CN3101e*1



Printer Version*2

For offices that primarily output from PC files, as well as those which require the fast and beautiful printing performance of colour and black & white documents.

CN3102e*1



Copier Version*2

For offices that require copies with sharp, clear and true-to-life images. This version offers you an environment where colour can be used with ease – precisely like black & white.

*1Printer controllers *2Can be upgraded to MFP version.



Colour Network Solutions for Efficient Business Use

Colour document management with the CF3102

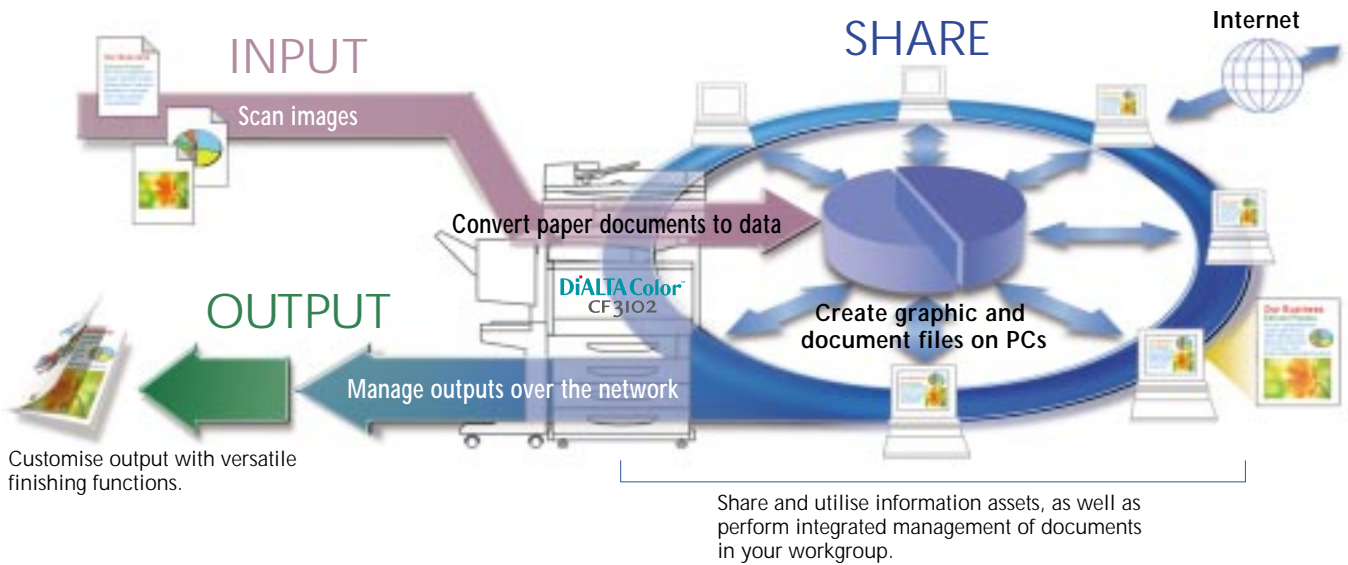

INPUT

Scan your colour documents into the CF3102 and combine them in a shared folder on the network. Now, key information assets can be shared at their maximum capacity with anyone in your workgroup to improve tangible and intellectual productivity.

CN3102e* CN3101e* *Requires either printer controller to perform the following functions.

Managing Paper Documents and Electronic Data Seamlessly

Scan to E-mail Scan to FTP
Scan to HDD

The versatile network scanning functions of the CF3102 support your office's information sharing, management and storage. Frequently used documents can be quickly and easily retrieved when necessary, enabling the rapid relay of information needed to increase communicational power.

Scan to E-mail Sending all data in colour

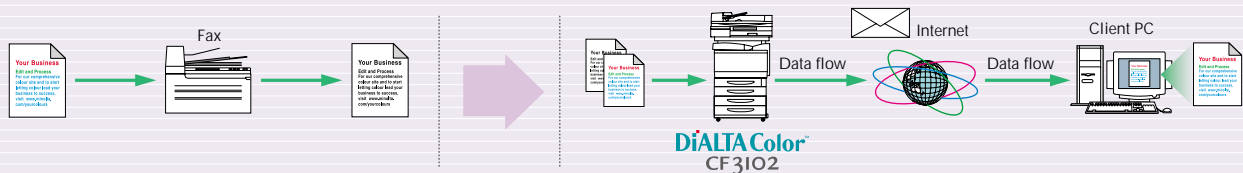

Send scanned data as e-mail. Increase business efficiency by successfully sending all data fast and in colour. Unlike faxes, received documents aren't required to be in black & white thus, they are easier to understand.

Scan to FTP Easy data sharing

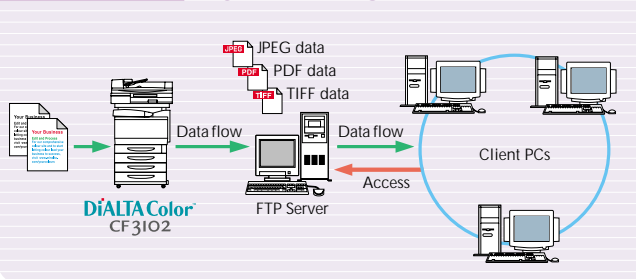

Save data on the FTP server to allow network users to share documents. Quickly retrieve data whenever needed.

Scan to HDD Easy data view & download

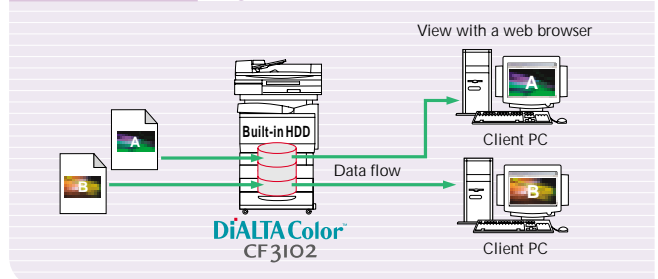

Share documents by storing them to the hard disk drive.* Easily view and download data from the client PCs.
*Requires the HDD-5 when using the CN3101e.

Expand Your Business Horizons. Edit and Process Shared Information.



SHARE and EDIT

Improve the tangible and intellectual productivity of your office by putting information to use via data sharing of downloaded digital photos, scanned images and documents on your network. Then, use those data with our colour network solutions to quickly edit and add colour, for more customised and persuasive proposals or promotional materials. Let us help you fine-tune your business correspondence with the following tools to lead your business to success.



For our comprehensive colour site, visit www.minolta.com/yourcolours

Boost Sales with Customised Plans and Direct Mail FreeForm CN3102e

Simply store the master data on the printer controller's hard disk drive, then merge it with the variable data as you print. This is ideal for diverse printing jobs like customised direct mail, fliers and proposals that target customer interests.

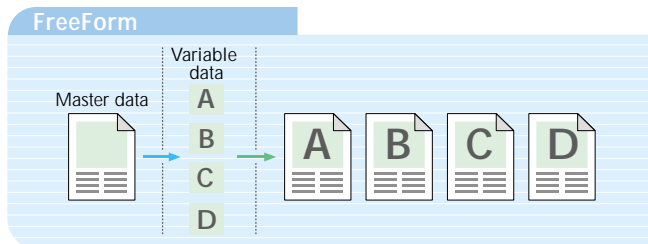

Beautiful In-house Booklet Making to Increase Sales and Work Efficiency

DocBuilder Pro* CN3102e

When binding data stored in the hard disk drive of the printer controller, DocBuilder Pro lets you create a variety of settings such as making two-sided outputs from different applications, exchanging pages, as well as deleting pages. This is the easy way to develop beautiful proposals and booklets in-house.

*Optional function when CN3102e is installed.

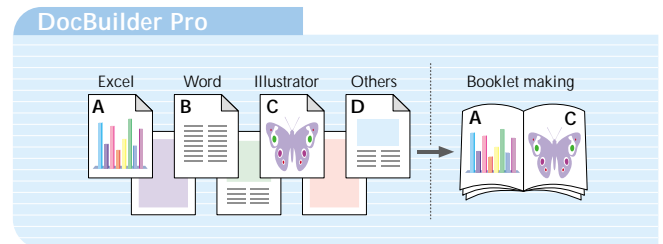

Software Solutions for Diverse Business Needs PageScope Suite CN3102e CN3101e

The CF3102 comes bundled with PageScope Suite software* that optimises features of Minolta's multifunctional peripherals. This software series enables easy device setup and efficient management within the office network. You also get exceptional document management for improved workflow efficiency.



PageScope Cabinet

*Bundled with the printer controllers CN3102e / CN3101e.

For our comprehensive PageScope Suite site, visit www.pagescope.com

Save on Long Distance Fees With an Internet Line

Internet Fax CN3102e CN3101e

This function enables you to use the CF3102 as an internet fax, allowing data to be sent via the internet. When compared to normal fax transmissions using PSTN, this method greatly reduces long-distance transmission fees.

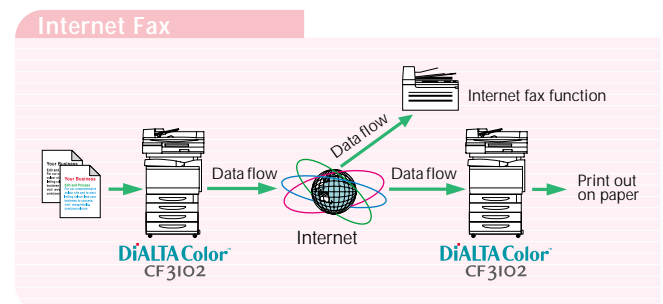

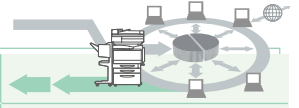

OUTPUT

The CF3102 supports you with higher productivity and faster results at 31 pages per minute in both colour and black & white outputs. By using convenient finishing functions, you can print small lots of diverse jobs like simple brochures, booklets and collateral completely in-house. The ability to create these unique materials gives you the advantages you need to lead your business to success.



Exceptional High-speed Colour Outputs

High-Speed Colour (31 pages/min) Enhanced ACS Control

Now, get the superb performance of high-speed output at 31 pages/min* in both colour and black & white high-volume output capability. Whereas previously there was a dramatic drop in speed, enhanced ACS Control can maintain a 31 page per minute maximum output of even mixed colour and black & white documents.

*A4 crosswise

Enhanced ACS Control

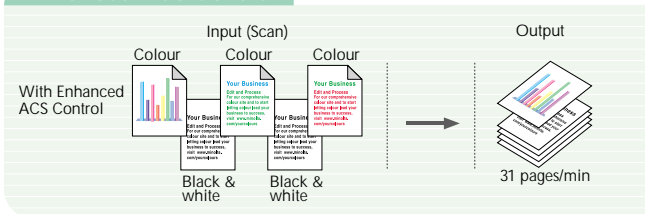

A Low-gloss Finish is Best for Business Documents Polymerised Toner

The CF3102 uses polymerised toner, which needs no oil for fusing. This produces natural-looking, low-gloss images of colour documents that can be written on as well as allow notes to be attached, and are suitable for business use. The small diameter and uniform shape of these toner particles also enable a stable supply of high image quality, with improved reproduction of text and fine lines.

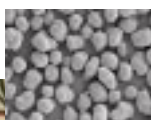

Imaging with CF3102



Imaging with previous model

Get True-to-life Colours That Satisfy Even Graphics Users

Minolta Advanced Color Conversion System (MACCS)

The unique Minolta Advanced Color Conversion System (MACCS) adds greater precision to the reproduction capabilities of colour tones such as sRGB Colour Matching, which decreases differences in reproduction between colours – an essential factor in colour copier/printer performance.

Sharp Reproduction of Coloured Text and Fine Lines

Tag Bit CN3102e

Tag bit produces sharper and clearer images of half-tone coloured text and fine lines by applying emphasis to the edges of text and lines.

Imaging with CF3102

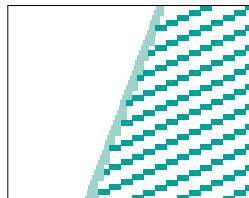

Imaging with previous model

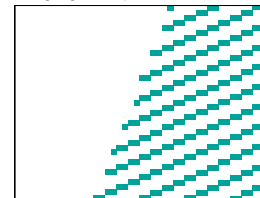

Highly Accurate Colour Image Quality

ColorWise 3.0 CN3102e

ColorWise 3.0 further strengthens colour management functions with new features. It boasts ColorCal, which has 256 randomly placed measuring patches that increase calibration accuracy. It also features AutoGray, which adjusts the gray balance to create a more neutral gray.

Productivity That Meets A Variety of Office Needs

Easy Sorting of Large-volume Jobs

Electronic Sorting

By having the paper trays filled in both the lengthwise and crosswise directions, you can designate alternate sorting and alternate group outputs using only the main unit. There is no need for a dedicated sorter, and as a result, less space is required.

Create Original Sales Promotion Materials In-house That Standout

Thick Paper, A3 Wide and Envelope Compatibility

The CF3102 is compatible to a variety of media like thick paper for presentation covers and envelopes for invitations. Also, conveniently select from a variety of paper sizes up to A3 wide, for print outs of rough comprehensives with crop marks or smaller, difficult-to-read charts.

Save Time and Increase Precision When Preparing Complex Materials

Finishing Functions

The versatile functions of the finishers shorten your office work time. Even mixed colour and black & white documents can be processed from output to stapling automatically and instantly. What's more, use of the FN-8 finisher allows you to easily create simple booklets and brochures to further meet your office's varied needs.

Finishing Functions	FN - 8	FN -116
Sort		
Corner staple	*1	*2
2-point staple (side)		—
Fold and Saddle-stitch	*3	—
Punch (4 holes) *4		—

*1 Up to 50 sheets of 80g/m² (A4 crosswise)

*2 Up to 30 sheets of 80g/m² (A4 crosswise)

*3 Up to 10 sheets of 80g/m²

Finishing Function Types of the FN-8 (for copying and printing)

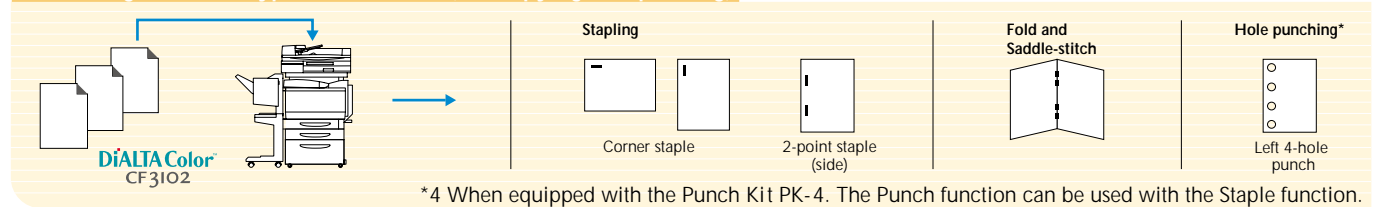

Processing grouped outputs with the CF3102

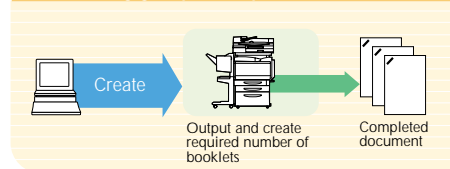

Previous steps required to create documents

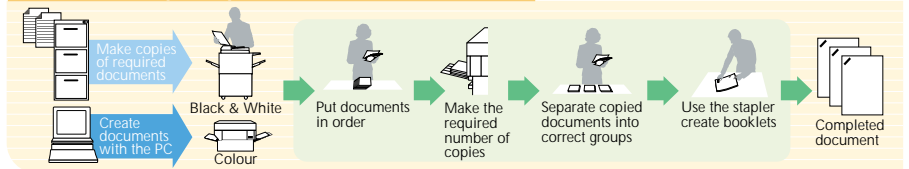

In-house Document Creation

Colour is more powerful than you can imagine. By adding it to your various business documents, you can create unlimited possibilities. Furthermore, your product proposals can be better expressed and emphasized, while effective in-house pamphlets can be created.

Presentations

Use colour photos and graphs as visual aids to capture customer attention.



Direct Mail

Create direct mail advertisements for each of your customers, while increasing the overall number of customers who see it.



Newsletters

Create more appealing reader friendly newsletters featuring photos in-house and in colour.



Booklet

Utilise beautiful colour to create pamphlets in-house for diverse printing.



Proposals

Make proposals attractive and persuasive by highlighting important messages in colour plus, incorporate logos to increase corporate identity.

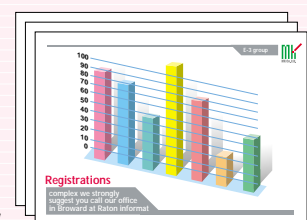

Processing A Variety of Jobs

The CF3102 can also store printer/copy jobs that can be managed easily from the control panel. Multiple operators can use the CF3102 simultaneously, resulting in jobs that are processed smoothly and without the wait.

Increase Priority

The order of all queued jobs can be changed to output jobs based on their priority, which is convenient for rush jobs.

Unlock Job (Printer Function of the MFP Version)

By inputting a password when printing from your PC, confidential documents will remain in the memory until your password is keyed-in at the CF3102, thus preventing a third party from viewing your outputs.

Memory Recall

Copy jobs and print data can be saved in the CF3102's memory, allowing additional copies to be recalled and reprinted. This feature is ideal for test copying as well as when making large volume re-prints because once data is saved in memory, there is no need to re-RIP. This feature increases print job productivity.

Combine Jobs

Up to 5 copy and print jobs from different applications can be combined, stored in the CF3102, and then printed as one document. When used with the CF3102's finishing functions, it becomes a useful feature for printing diverse meeting documents.

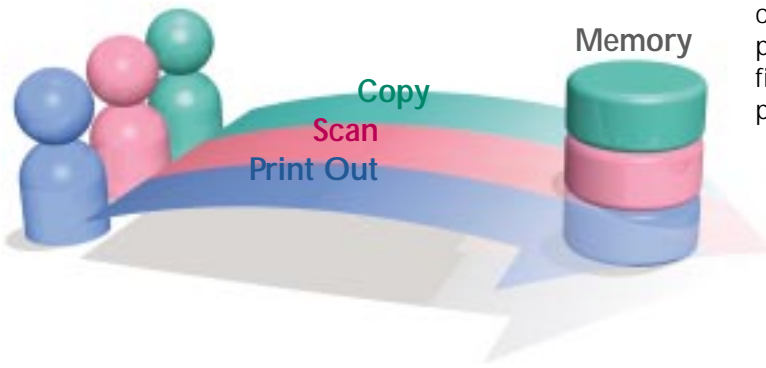

Combine Jobs Function Screen

An Inviting, User Friendly Design

The CF3102 provides a host of worry-free functions that allow everyone in the office to use it with the same ease as using a black & white copier.

Toner Cartridge

Minolta adopted cartridge-type toner to make toner replacement ultra simple, cleaner and less time consuming.



Space-saving Design

Even with all of its functions, the CF3102 is ultra-compact. Notably, the wingless design of the Automatic Document Feeder further reduces the footprint.

Universal Design

The CF3102's control panel has a 3-step angle of adjustment (7, 27 and 45 degrees) for maximum viewing and operating ease. It features easy-to-read panel indicators that display white symbols against a dark background. In addition, you get grip-type handles on the paper cassette trays for effortless opening and closing.



Extended Consumable Life

Increasing the durability and life of each consumable unit has reduced the machine's downtime. Users can now avoid unexpected run outs of consumables by monitoring their use on the CF3102's control panel.



Minolta CS Colour Technologies are incorporated into the DiALTA Color CF3102

Image quality, productivity, operability, reliability, connectivity and environment. We've reexamined these six features, essential in all business equipment, to create Minolta's unique colour image information products. The DiALTA Color CF3102, using these innovative CS Colour Technologies, provides efficient document work for complete customer satisfaction.

CF3102 Specifications

General

Type: Digital Full-Colour Copier/Printer/Scanner
 Process: Tandem Type Indirect Electro-photographic System
 Gradation: 256 gradations
 Memory: 256MB Standard
 Warm-Up Time: 300 seconds or less
 Power Consumption: 1.5kW
 Dimensions: Scanner: 589 (W) x 730 (D) x 152 (H) mm
 (23-1/4" x 28-3/4" x 6")
 Main Unit: 596 (W) x 730 (D) x 571 (H) mm
 (23-1/2" x 28-3/4" x 22-1/2")
 Weight: Scanner: 19.5kg (43-3/4 lbs.)
 Main Unit: 85kg (187-1/2 lbs.)

Paper Handling

Type of Originals: Sheets, Book, 3-D Objects
 Original Size: Max.: A3 (Ledger)
 Paper Capacity: Standard: 751 sheets (250 + 500 + 1)
 Max.: 3251 sheets (250 + 500 + 1 + 2500)
 Output Size: A3 Wide (311 x 457 mm) to A6
 (12-1/4" x 18" to 3-1/2" x 5-1/2")
 Materials: Plain Paper (64-90g/m²)
 Thick Paper 1 (91-150g/m²)*
 Thick Paper 2 (151-209g/m²)*
 Thick Paper 3 (210-256g/m²)*
 Envelopes*/OHP*
 *1st drawer and Manual Bypass Tray

Copy

Copy Speed: Colour: 31 pages/min (A4 crosswise)
 B&W: 31 pages/min (A4 crosswise)
 Colour 9.9 seconds or less (A4 crosswise)
 B&W 7.9 seconds or Less (A4 crosswise)
 1st Copy: Scan 600dpi x 600dpi
 Resolution: Copy 600dpi x 1800dpi equivalent
 x 0.250 - 4.000 (Preset or Variable)
 Magnification: Text / Photo, Photo Image, Printed Image,
 Exposure Modes: Text, Map, Copied Image

Controller CN3102e/CN3101e Specifications*

*Some functions are not available for the Printer Version.

■ CN3102e

General

CPU: Intel Pentium III 700MHz
 Memory: Roman 128MB (Max. 256MB)
 HDD: 10GB
 Operating System: Windows 98/Me, Windows NT 4.0/2000/XP,
 Macintosh 8.6 or above, Macintosh OS X classic mode, UNIX
 Interface: IEEE1284 (Compatible/Nibble/ECP) Ethernet (10/100
 BASE-TX, RJ45)
 Network Protocols: AppleTalk (EtherTalk), TCP/IP (LPD, SMB, PORT9100,
 IPP, HTTP), IPX/SPX (NDS)
 Software: PageScope Light (Embedded), PageScope Net Care,
 PageScope Network Setup, PageScope EMS Plug-Ins,
 PageScope NDPS Gateway, PageScope Cabinet
 Job Management: FreeForm, Command Work Station (Fiery Utility),
 Job Merge/Edit (Fiery Utility)
 Color Management: ICC/ICM Profile, Color Wise Pro.Tool, Smooth Scale
Print
 Speed: 31 pages/min (Colour/B&W, A4 crosswise)
 Resolution: 600dpi x 1800dpi equivalent
 Printer Languages: Adobe PostScript 3, PCL5c
 Fonts: Adobe Type1 (136 fonts), 45 scalable PCL fonts

Scan

Speed: 31 pages/min (Colour/B&W, A4 crosswise)
 Resolution: 200/300/400/600dpi
 Data Format: PDF, JPEG, TIFF6.0

Internet Fax

Internet Protocol: Send: SMTP Receive: POP3, IMAP
 E-mail Format: MIME
 Data Format: TIFF-S
 Data Compression Mode: MH compression (TIFF-S)
 Scan Resolution: 200dpi x 200dpi
Options
 DocBuilder Pro (Fiery Utility) for Ver.1.5, EFI Densitometer

■ CN3101e

General

CPU: MPC8240-200MHz (Shared with machine's main body.)
 Memory: 160MB (Max.)
 HDD: Shared with CF3102's optional Hard Disk Drive.
 Operating System: Windows 98/Me, Windows NT4.0/2000/XP
 Interface: IEEE1284 (Compatible/Nibble/ECP), USB (Ver.1.1),
 Ethernet (10/100BASE-TX, RJ45)
 Network Protocols: TCP/IP (LPD, Rawport, SMB, FTP, IPP1.0, POP3, SMTP),
 IPX/SPX

Software:

PageScope Light (Embedded), PageScope Net Care,
 PageScope Network Setup, PageScope EMS Plug-Ins,
 PageScope NDPS Gateway, PageScope Cabinet

Color Management:

Identical to machine's main body.
Print
 Speed: 31 pages/min (Colour/B&W, A4 crosswise)
 Resolution: 600dpi x 1800dpi equivalent
 Printer Languages: PCL5c
 Fonts: 45 scalable PCL fonts

Scan

Speed: 31 pages/min (Colour/B&W, A4 crosswise)
 Resolution: 200/300/400/600dpi
 Data Format: PDF, JPEG, TIFF

Internet Fax

Internet Protocol: Send: SMTP Receive: POP3
 E-mail Format: MIME
 Data Format: TIFF-S
 Data Compression Mode: MH compression (TIFF-S)
 Scan Resolution: 200dpi x 200dpi

OPTIONS

Option Tray JS-100

With the Finisher FN-116 installed, copies, printouts and Internet fax outputs can have their own output trays.



Finisher FN-116

Single-staples and sorts sets of up to 30 sheets each.



Hard Disk Drive HDD-5

Increases the number of pages that can be stored in the memory plus, enables the stamping of "Distribution" numbers.

Memory M256-2

Increases unit memory to 512MB (256MB standard + 256MB expanded).

Finisher FN-8

A high-performance finisher that can sort, multi-staple and hole punch sets of up to 50 sheets, as well as booklet bind sets of up to 10 sheets.



Duplexing Document Feeder AFR-18

Can set up to 100 sheets of two-sided originals (80g/m²) for automatic duplex copying.



Original Cover OC-2



Main body + PF-118 x 2
 OC-2 + CS-2 + CT-2



Printer Controller CN3102e with I/F Kit P*

The embedded printer controller series allows the copier to be used as a colour printer and scanner. *option for CN3102e

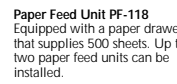

Paper Feed Unit PF-118
 Equipped with a paper drawer that supplies 900 sheets. Up to two paper feed units can be installed.



Copy Table CT-2

Other Options
 Printer Controller CN 3101e
 Punch Kit (PK-4) *Option for FN-8
 Data Controller D-103
 Data Terminal DT-103



Duplex Unit AD-14
 Provides duplex copying using the non-stack method.



Large Capacity Cabinet PF-121
 Equipped with a paper drawer that supplies a max. 2,500 sheets.

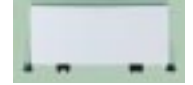

Copy Desk CD-2M

Copier Stand CS-2

Place the scanner on top and the printer inside, to reduce installation space.



Product appearance, configuration and/or specifications are subject to change without notice.

DIALTA and PageScope are registered trademarks or trademarks of KONICA MINOLTA BUSINESS TECHNOLOGIES, INC. Fiery and the Fiery logo are registered trademarks with the U.S. Patent and Trademark Office and certain other foreign jurisdictions. FreeForm and DocBuilder are trademark of Electronics for Imaging, Inc. Windows is a registered trademark or trademark of Microsoft Corporation. Adobe and PostScript are registered trademarks or trademarks of Adobe Systems Incorporated. All other brand and product names are registered trademarks or trademarks of their respective owners.

*As an ENERGY STAR Partner, KONICA MINOLTA BUSINESS TECHNOLOGIES, INC. has determined that this product meets the ENERGY STAR guidelines for energy efficiency.

*ENERGY STAR is a U.S. registered mark.

Minolta copiers and multi-functional peripherals are designed with the environment in mind.



Meets ENERGY STAR Guidelines
 The Use of Recycled Materials
 Lead-free Wiring
 110W Low-power Mode
 (a 40% Reduction from Previous Minolta Models)
 Recyclable Toner Cartridge
 Production at ISO-certified Factories

Minolta Genuine Consumables and Parts

To ensure the best possible use of our copiers in terms of cost, copy quality and service life, Minolta has extended its technical expertise as a manufacturer of precision equipment to the development and production of high-quality consumables and parts. For optimum performance and productivity, we recommend the use of Minolta's genuine consumables and parts.

KONICA MINOLTA BUSINESS TECHNOLOGIES, INC.

1-6-1 Marunouchi Chiyoda-ku, Tokyo, Japan

http://www.imageinfo.konicaminolta.net



This catalogue was printed using recycled paper and soy ink.